



## **6610003 7:1 Forward Swing Brake Pedal Instructions**



**AFCO RACING**  
**P.O. Box 548, Boonville, IN 47601**  
**(800)-632-2320**  
**[www.AFCOracing.com](http://www.AFCOracing.com)**

LIT3014 Rev. 2, Copyright 2016 - AFCO Performance Group

## **WARNING**

Proper installation and setup of the brake system is extremely important for the safety of the vehicle. The specifications and recommendations contained within this document must be followed to ensure safe installation and operation of the brake pedal system. Failure to do so may result in severe injury to not only the driver of the vehicle but others around the vehicle.

AFCO is not responsible for any product that has been improperly installed, crashed, welded to, or modified in any way. AFCO does not cover damage to any related components as a result. Neither the seller nor AFCO will be responsible or liable for any loss, damage, or injury resulting from the direct or indirect use of this product or inability by the purchaser to determine the proper use or application of this product.

---

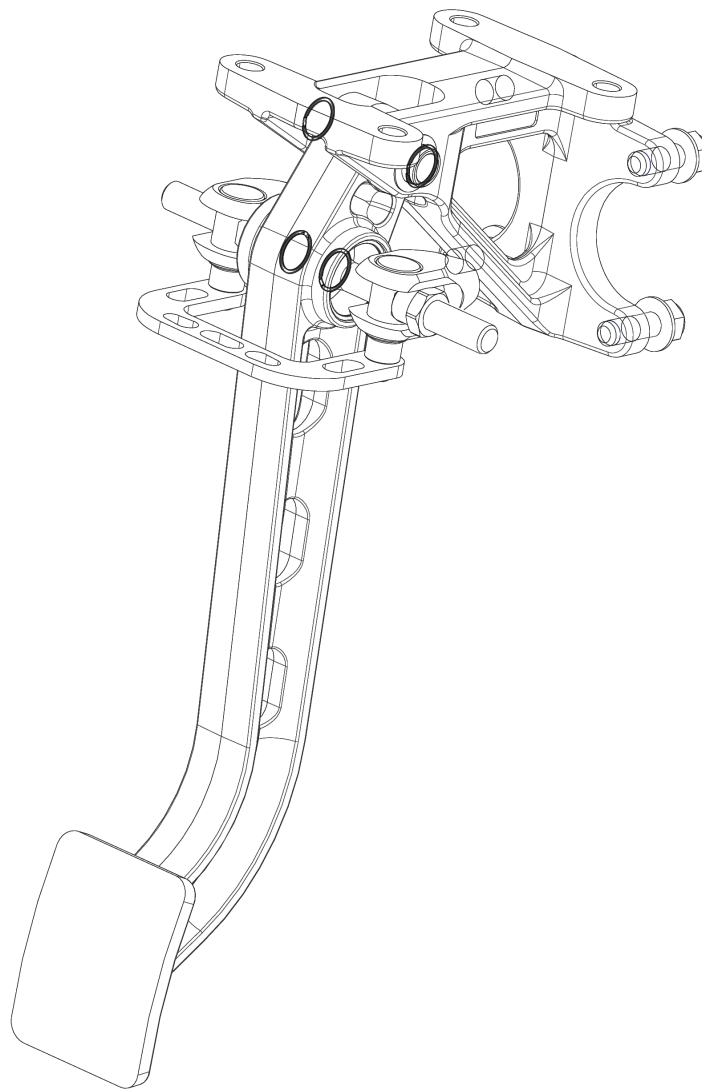

## Installation Instructions:

1. The center-to-center distance of the bias bar clevises should be set to 2.63 inches. As an added convenience, AFCO pedal assemblies include a bias rod tie-bar that maintains the correct 2.63 inch spacing.
2. Loosen the bias rod jam nut. If using a remote bias adjuster, remove the bias rod jam nut.
3. Thread the bias bar all the way to one side until it hits the internal stops then turn it back 11 full turns. This will center the bias rod bearing in the bore to set the neutral position of the bias bar. The neutral position is where the force applied between the front and rear master cylinder is equal.
4. If a more accurate setting method is desired, the distance between the outer edge of one of the clevises and the end of the bias rod (with the recessed HEX) can be set to exactly 0.66 inches. Refer to Figure 1.
5. Tighten the bias rod jam nut to 23 ft. lbs. if not using a remote adjuster.
6. Bench bleed the master cylinders and mount them to the pedal assembly using the supplied nylon lock flange nuts. Torque the nuts to 18 ft. lbs.
7. Ensure each master cylinder push rod has a jam nut installed, then, thread each master cylinder push rod into the corresponding clevis roughly 1/2 inch.
8. At minimum, the pedal assembly must be mounted using the (4) 5/16 inch holes on the base plate. The (4) 1/4-20 auxiliary mounting holes may also be used for further rigidity.
9. Mount the pedal assembly to the chassis using grade 8, 5/16 bolts, nuts, and washers. Use of a lock nut or lock washer is recommended. Torque the mounting bolts to 29 ft. lbs.
10. Stroke the pedals and check that there is no interference between the pedals and chassis throughout the entire range of motion.
11. Attach the brake hydraulic lines, ensuring they are clear of any sources of excessive heat and moving parts. Follow the manufacturer's instructions for proper filling and bleeding of the brake system.
12. Once the brakes are properly bled, proceed with bias bar setup according to the Bias Bar Setup instructions.

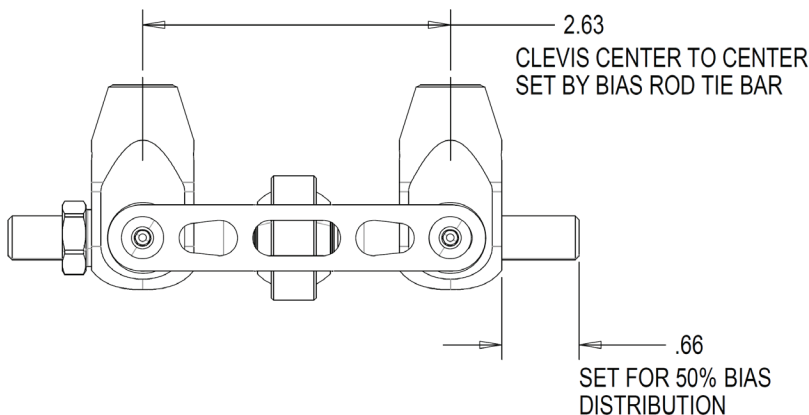

FIGURE 1: Bias Bar Neutral Position

<b>TORQUE SPECIFICATIONS</b>		
<b>Component</b>	<b>Thread Size</b>	<b>Torque</b>
Push Rod Jam Nut	5/16-24	12 ft. lbs.
Master Cylinder Retaining Nuts	5/16-24	18 ft. lbs.
Master Cylinder Studs	5/16-18	11 ft. lbs.
Bias Rod Tie Bar Screws	#10-24	27 in. lbs.
Pedal Mount to Chassis Bolts	5/16-18	29 ft. lbs.
Bias Rod Jam Nut	3/8-24	23 ft. lbs.

TABLE 1: Product Torque Specifications

### Bias Bar Setup:

1. Adjust the push-rod thread engagement until the position of each pedal is correct for the driver. **Note: Setting the “downswing” pedal position in such a way that a firm pedal occurs beyond the lowest point of its stroke is not advised. This will reduce the mechanical advantage of the pedal and effect pedal feel.**
2. Check that the pedal position allows for adequate pedal stroke and allows the master cylinders to return to their fully relaxed position without binding.
3. Apply firm pressure to the pedal to engage the brakes. Adjust the master cylinder push rods by equal amounts in opposing directions until the bias bar is parallel with the master cylinder mounting surface. If one push rod is loosened by 2 turns, tighten the other by 2 turns. This will maintain the pedal position set previously.
4. The bias rod should now be square with the pedal mount when the pedal is depressed. When the pedal is relaxed, the bias bar may or may not be at an angle. Ensuring the bias bar is square under compression will engage the front and rear brakes simultaneously. Refer to Figure 2.
5. A minimum push rod thread engagement of 5/16 inches, or 8 turns, is recommended. If push rod thread engagement is less than recommended, the pedal position must be adjusted and steps 2 through 4 must be repeated.
6. If the push rod engagement is greater than 1/2” and extends into the center of the slotted clevis, trim the master cylinder push rod to the correct length to prevent interference with the bias rod. Repeat steps 2 through 5.
7. Tighten each push rod jam nut to 12 ft. lbs.
8. Stroke both pedals again and ensure there is no binding, interference, or bottoming between components or the chassis.
9. Loosen the jam nut on the bias bar and adjust the bias bar completely to the left. Stroke the pedal assembly and ensure there is no interference or binding. Repeat the process with the bias bar adjusted completely to the right.
10. Return the bias bar to its centered position using steps 3 through 5 on page 3.
11. The bias bar is now properly set-up. However, further changes need to be made in order to properly adjust front to rear bias. Refer to page 5 for proper bias bar adjustment.

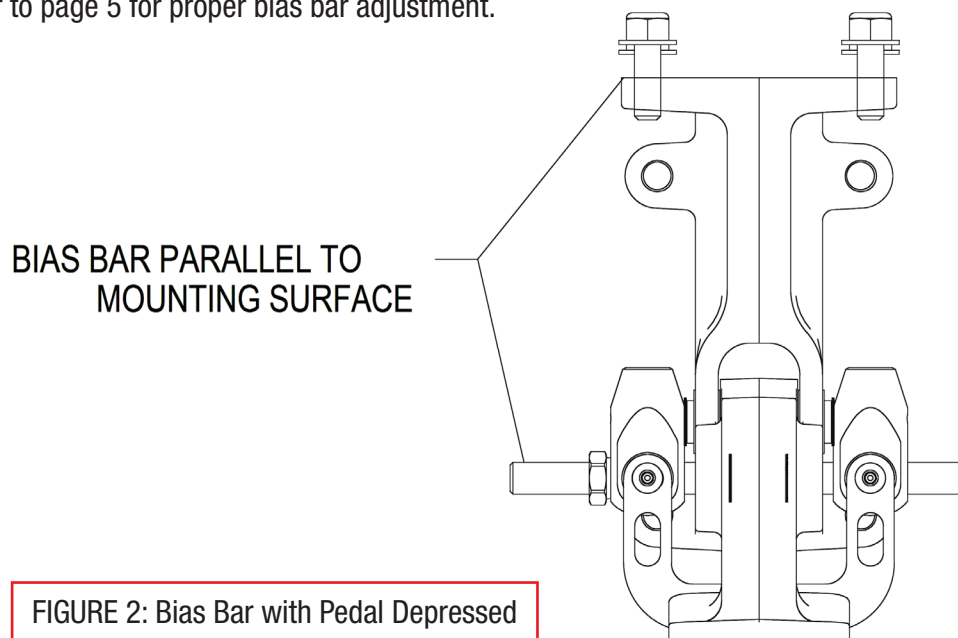

## Bias Bar Adjustment Procedure:

### Without remote adjuster:

1. The bias bar should be adjusted so that the bearing is closer to the master cylinder for the axle that should lock up first. For pavement racing or street applications, the front wheels should always lock up before the rear wheels.
2. Loosen the jam nut on the bias bar using a 9/16" wrench.
3. Turn the bias bar by hand or by using the recessed 3/16" hex (Figure 3) in the end of the bias bar to set the desired spherical bearing position.
4. Use Table 2 as a reference when making bias adjustments to estimate force distribution between master cylinders.
5. After making a bias adjustment, tighten the bias bar jam nut to 23 ft. lbs.

### With remote adjuster:

1. Ensure the bias adjuster is securely fastened to the bias bar per the manufacturer's instructions.
2. **Remove the bias bar jam nut; it will not be used with a remote adjuster.**
3. To quickly find the center of force distribution, turn the bias adjuster completely in one direction until it stops. Turn back 11 full turns to locate approximate center.
4. For safety, it is recommended that the starting position of the bias bar be set to cause the rear axle to lock first.
5. Use table 2 as a reference when making bias adjustments using the remote adjuster cable.

<b>BIAS BAR FORCE DISTRIBUTION</b>			
Bearing Position	Bias Setting (# of Turns)	Left Clevis Force	Right Clevis Force
1/2" Left of Center	12 Left	69.3%	30.7%
	11 Left	67.7%	32.3%
	10 Left	66.1%	33.9%
3/8" Left of Center	9 Left	64.5%	35.5%
	8 Left	62.9%	37.1%
	7 Left	61.3%	38.7%
1/4" Left of Center	6 Left	59.7%	40.3%
	5 Left	58.0%	42.0%
	4 Left	56.4%	43.6%
1/8" Left of Center	3 Left	54.8%	45.2%
	2 Left	53.2%	46.8%
	1 Left	51.6%	48.4%
<b>Centered</b>	<b>Centered</b>	<b>50.0%</b>	<b>50.0%</b>
	1 Right	48.4%	51.6%
	2 Right	46.8%	53.2%
	3 Right	45.2%	54.8%
1/8" Right of Center	4 Right	43.6%	56.4%
	5 Right	42.0%	58.0%
	6 Right	40.3%	59.7%
1/4" Right of Center	7 Right	38.7%	61.3%
	8 Right	37.1%	62.9%
	9 Right	35.5%	64.5%
3/8" Right of Center	10 Right	33.9%	66.1%
	11 Right	32.3%	67.7%
	12 Right	30.7%	69.3%

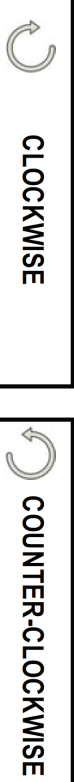

**TABLE 2: Bias Bar Force Distribution**

**TABLE 2: Bias Bar Force Description**

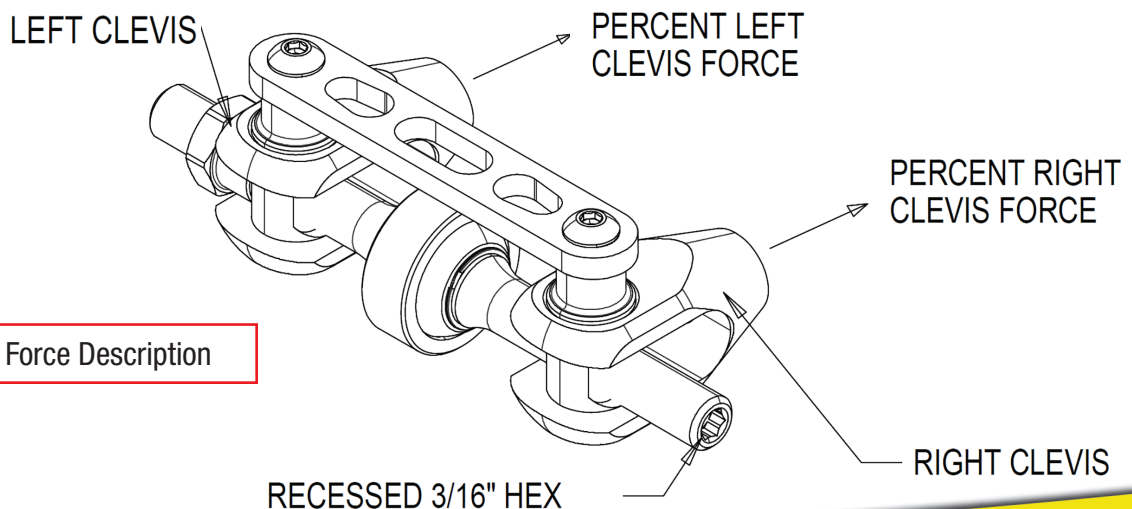

**FIGURE 3: Bias Bar Force Description**

## Troubleshooting:

- *Bias bar does not provide adequate force distribution or runs out of adjustment before desired force distribution is achieved:*

The master cylinders are most likely sized inappropriately. A master cylinder bore size change must be made to the system. Changing to a smaller bore size will generate more line pressure with the same pedal force input but will require more pedal stroke. To maintain pedal stroke and generate more differential bias, decrease the bore size of one master cylinder and increase the other master cylinder size by the same amount.

- *Bias bar no longer pivots properly or does not adjust:*

The bias bearing and bore are likely filled with dirt and debris. Disassemble the bias bar assembly and thoroughly clean. Reassemble the bias bar and grease the bearing and bore lightly. The bias bar could also be slightly bent. This can happen if the pedal was depressed during a collision. Check the bias bar to ensure that it is not bent.

- *Pedals and/or master cylinders bottom out before adequate braking force is generated:*

There is air in the brake system. Rebleed the master cylinders if necessary and follow by properly bleeding the system at each caliper.

- *When using a remote adjuster, the bias bar sticks or locks-up at the end of the range:*

The bias bar has been adjusted beyond its intended operating range. If more differential bias is desired a master cylinder size change may be necessary. Refer to the first troubleshooting bullet point above for information regarding size changes to the master cylinders.

- *Brake pedal gets softer toward end of stroke:*

Check that firm pedal and full brake engagement occurs before the pedal passes the lowest point of its “downswing”. If the pedal crosses the imaginary vertical centerline before full engagement occurs then the mechanical advantage lessens and pedal feel will be affected.

- *Pedal assembly feels like it is flexing:*

Often the support structure of the chassis is less rigid than the pedal assembly itself. Observe the mounting structure and note any flex that is visible when the pedals are depressed. If flex of the support structure is observed, the support structure of the chassis will need to be enhanced.

**Basic Product Dimensions - 6610003**

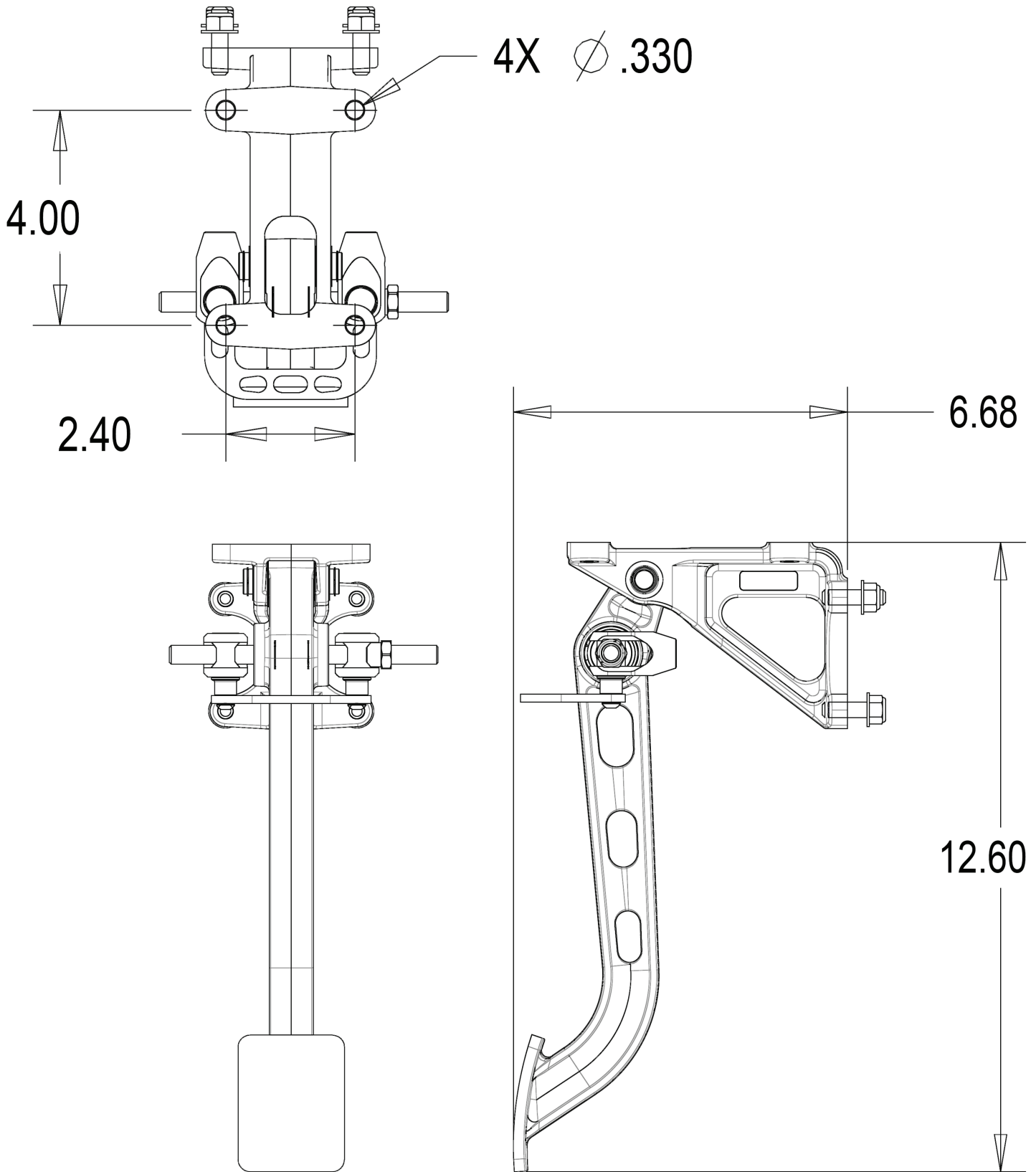



## CHECK US OUT ON THE WEB!

AFCO has been dedicated to building speed, power and performance for over three decades. For more information on our Suspension, Cooling and Brake components, find us online at [AFCOracing.com](http://AFCOracing.com).

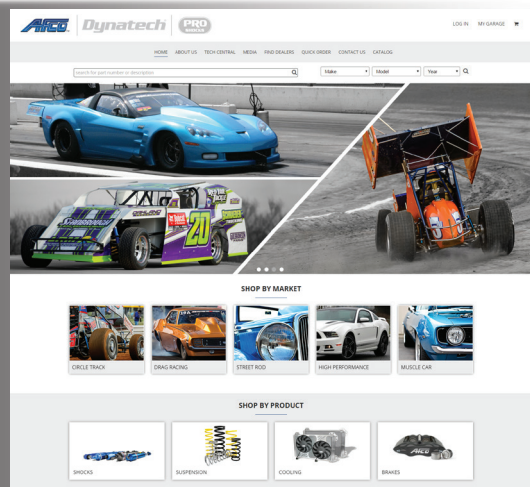

## FOLLOW US ON FACEBOOK!

For the latest news from AFCO Racing Products on new product development, technical bulletins, travel schedules, how-to manuals and event results, find us online at [facebook.com/AFCORacingProducts](http://facebook.com/AFCORacingProducts).

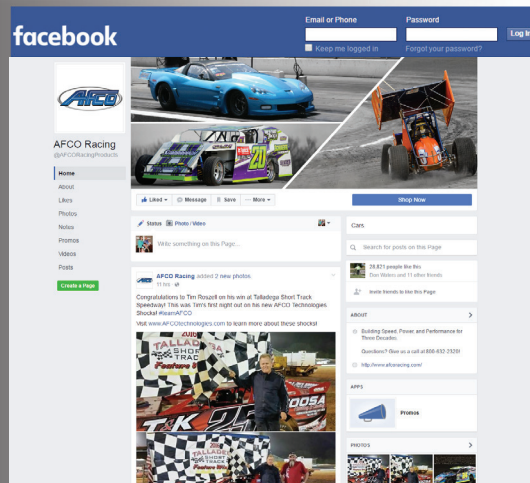

Stay connected

[www.AFCOracing.com](http://www.AFCOracing.com) | [AFCOracingcs@AFCOracing.com](mailto:AFCOracingcs@AFCOracing.com)  
800-632-2320 | 977 Hyrock Blvd. Boonville, IN 47601

LIT3014 Rev. 2, Copyright 2016 - AFCO Performance Group